

Loading Machine | Efficient handling in modern scrap recycling

ENGINE	148 kW 198 hp
WEIGHTS	32 t - 35.5 t 70,548 lbs - 78,264 lbs
REACHES	16/15/14 m (52'/49'/46')

SCRAP RECYCLING MACHINE
MHL 350

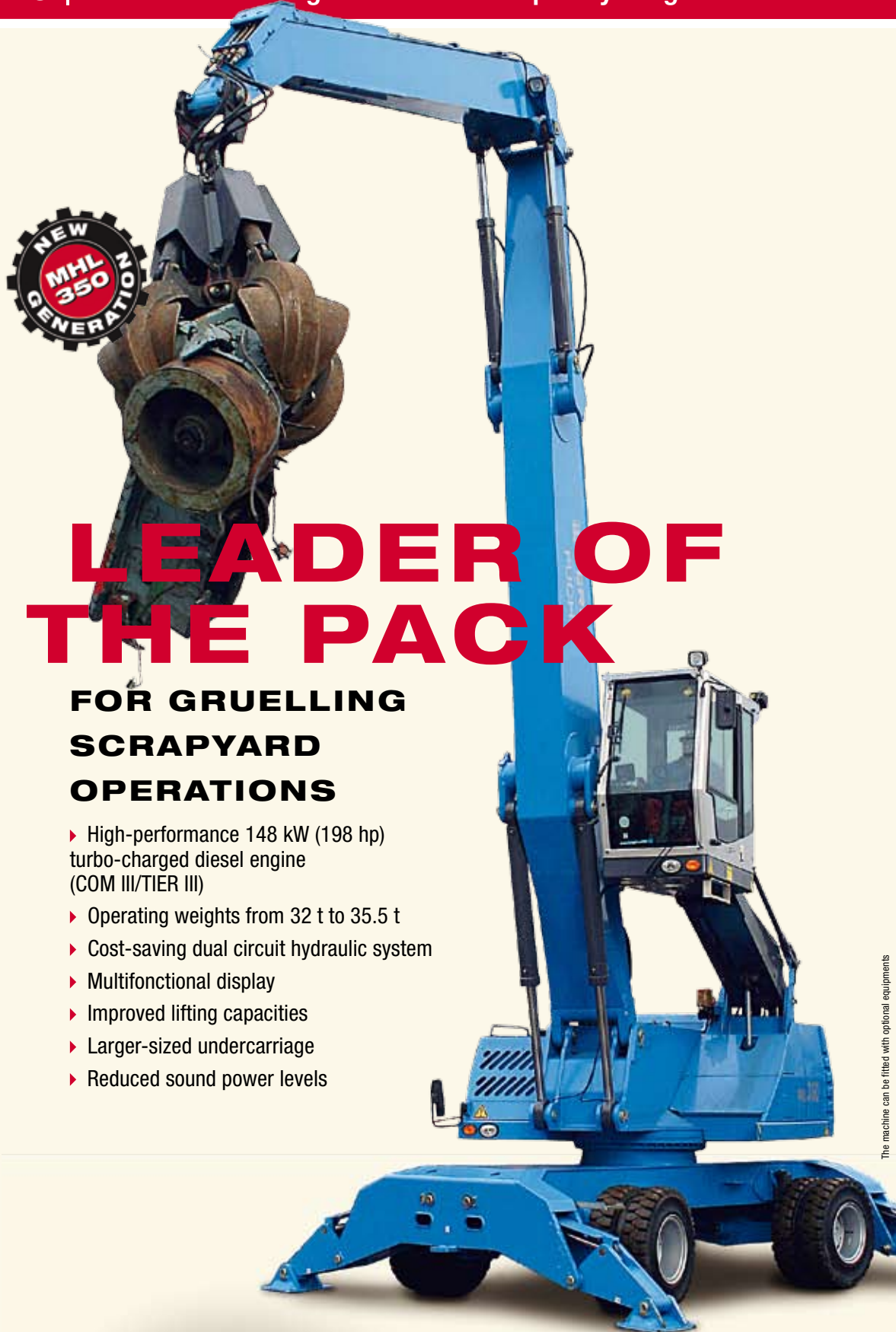

LEADER OF THE PACK

FOR GRUELLING SCRAPYARD OPERATIONS

- ▶ High-performance 148 kW (198 hp) turbo-charged diesel engine (COM III/TIER III)
- ▶ Operating weights from 32 t to 35.5 t
- ▶ Cost-saving dual circuit hydraulic system
- ▶ Multifunctional display
- ▶ Improved lifting capacities
- ▶ Larger-sized undercarriage
- ▶ Reduced sound power levels

**THE POWER LURKING IN THIS
MAKES IT READ**

**ULTRA ECONOMIC EFFICIENCY, OUTSTANDING
LIFTING CAPACITIES, RAPID POWER CYCLES
AND MODEL DRIVING COMFORT.**

The new MHL 350 (Series-D) is the embodiment of everything essential to insuring maximum performance in material handling environments.

- ▶ Larger-sized undercarriage (width: 3.0 m) for hefty lifts
- ▶ High traction performance from 148 KW (198 hp) engine with exceptionally low emission values and sound levels
- ▶ Dual circuit hydraulic system for smooth power cycles
- ▶ Optimized kinematics design provides higher lifting capacities
- ▶ Electronic engine control (EMR III) system for superior engine management
- ▶ Multi color display in the cab allows monitoring essential engine data
- ▶ Up to-date design of counterweight, headlamps and fairings



NEW TEREX FUCHS LOADER MHL 350 FOR ANY CHALLENGE

GREATER WIDTH OF STABILIZING SYSTEM

Larger outrigger cylinders and wider stabilizer support beams provide a larger width of the stabilizing system for increased stability and higher lifting capacities.

NEW KINEMATICS

The new loading attachment kinematics system, combined with a new boom design, enables higher lifting capacities across the full operating range.

In addition to the working attachments with a reach of 14 m and 15 m, a 16 m version is now available.

NEW PROVIDER OF PERFORMANCE LIFTING SOLUTIONS: ENORMOUS CAPACITIES, WIDE REACH AND HIGH LOADING PERFORMANCE

The way to repeated sure-fire success. The new MHL 350 (Series-D) enters new realms of lifting capacity, reach and loading performance.



LIFTING CAPACITIES SPECS

AT A GLANCE

- ▶ Greater lifting capacities and outreach due to new dimensions of undercarriage (width 3,0 m) and optimized lifting kinematics
- ▶ Increased maximum operating weight



A STOUT HEART

GENTLY THROBS WITH STAYING POWER CAST IN IRON

The MHL 350 (Series-D) is powered at 2000 rpm by a 148 KW (198 hp) Deutz engine with extremely cost-effective fuel consumption.

THE MACHINE THAT'S EASY ON THE EARS

The engine is phenomenally easy on the ears – sound levels have been lowered by more than 3 db. A low-noise pump and the proven, separate cooling-system, large radiator and low fan speed contribute to the quiet operation of the machine.

LOAD SENSING CONTROL - EFFICIENCY AS STANDARD

The engine is equipped with state-of-the-art technology. The load sensing control ensures optimum utilization of engine performance in every speed range. The engine thus disposes an efficient overload protection.

GOOD FOR THE ENVIRONMENT

Full compliance with exhaust legislation Com III and Tier III.

ENGINE SPECS

AT A GLANCE

- ▶ 148 kW (198 hp) strong turbo-charged Deutz engine
- ▶ Low noise emission
- ▶ Optimum performance utilization in every speed range

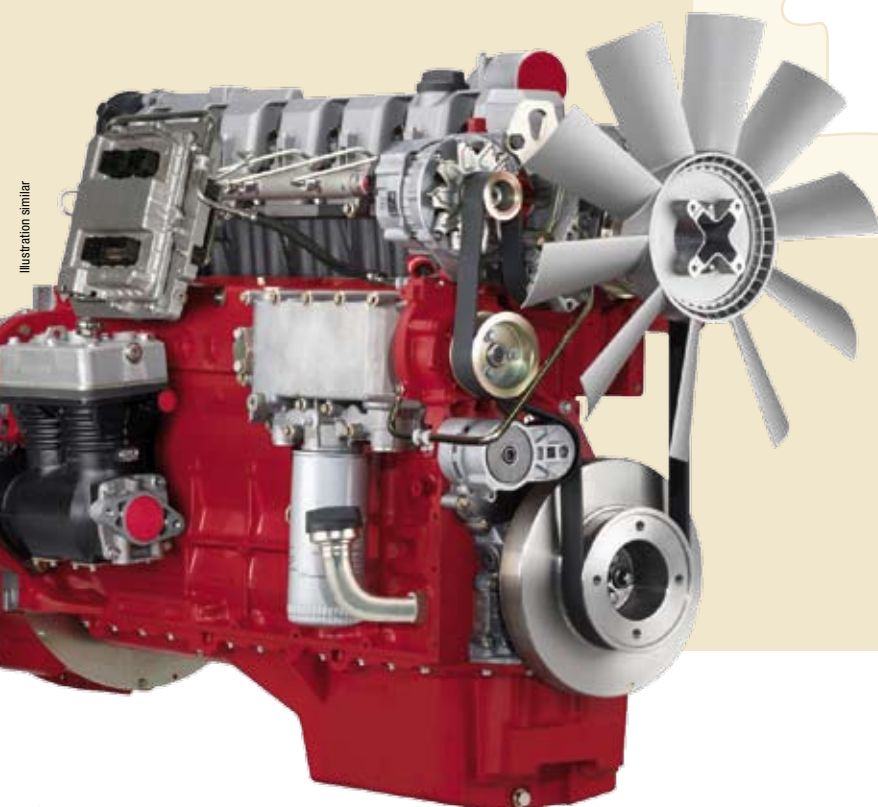

Illustration similar

CAB SPECS

AT A GLANCE

- ▶ Unobstructed all-round visibility
- ▶ Ergonomically designed operator station
- ▶ Comfortable orthopedically supportive air cushioned seat
- ▶ Air conditioning as standard
- ▶ Adjustable steering column

What conditions conduce to high levels of concentration? We've taken great care to develop a cab that integrates a variety of operators' suggestions as standard.



CAB ENHANCES OPERATOR'S PERSONAL BEST WORTH TAKING



NCE

KEEPING OPERATOR FATIGUE TO A MINIMUM

- ▶ Permanent visual contact with equipment and load through unobstructed all-round visibility in cabin capable of hydraulic elevation
- ▶ Light and spacious interior
- ▶ Ergonomically designed operator station that adapts to operator needs and not vice versa

COMFORT YOU'D EXPECT AT HOME

Seat comfort provided by an orthopedically contoured air cushioned seat with lumbar support, arm and headrests.



A NEW KIND OF EFFICIENCY

MORE EFFECTIVE. MORE PRODUCTIVE. MORE ON LESS.

THE RIGHT AMOUNT OF POWER

Whether you're dealing with rapid power cycles or unwieldy loads – the job on hand is provided hydraulic performance at the exact doses needed. Which makes for excellent fuel efficiency and keeps operating costs down.



THE FEEL-GOOD FACTOR

The system more than satisfies through a harmonic, virtually jolt-free operability. It provides both proportional control and also overlapping work motions irrespective of load.



INNOVATIVE DUAL CIRCUIT HYDRAULIC SYSTEM PROVIDES BOTH HIGH PRECISION HANDLING AND FREEDOM IN WORK MOTIONS

CY

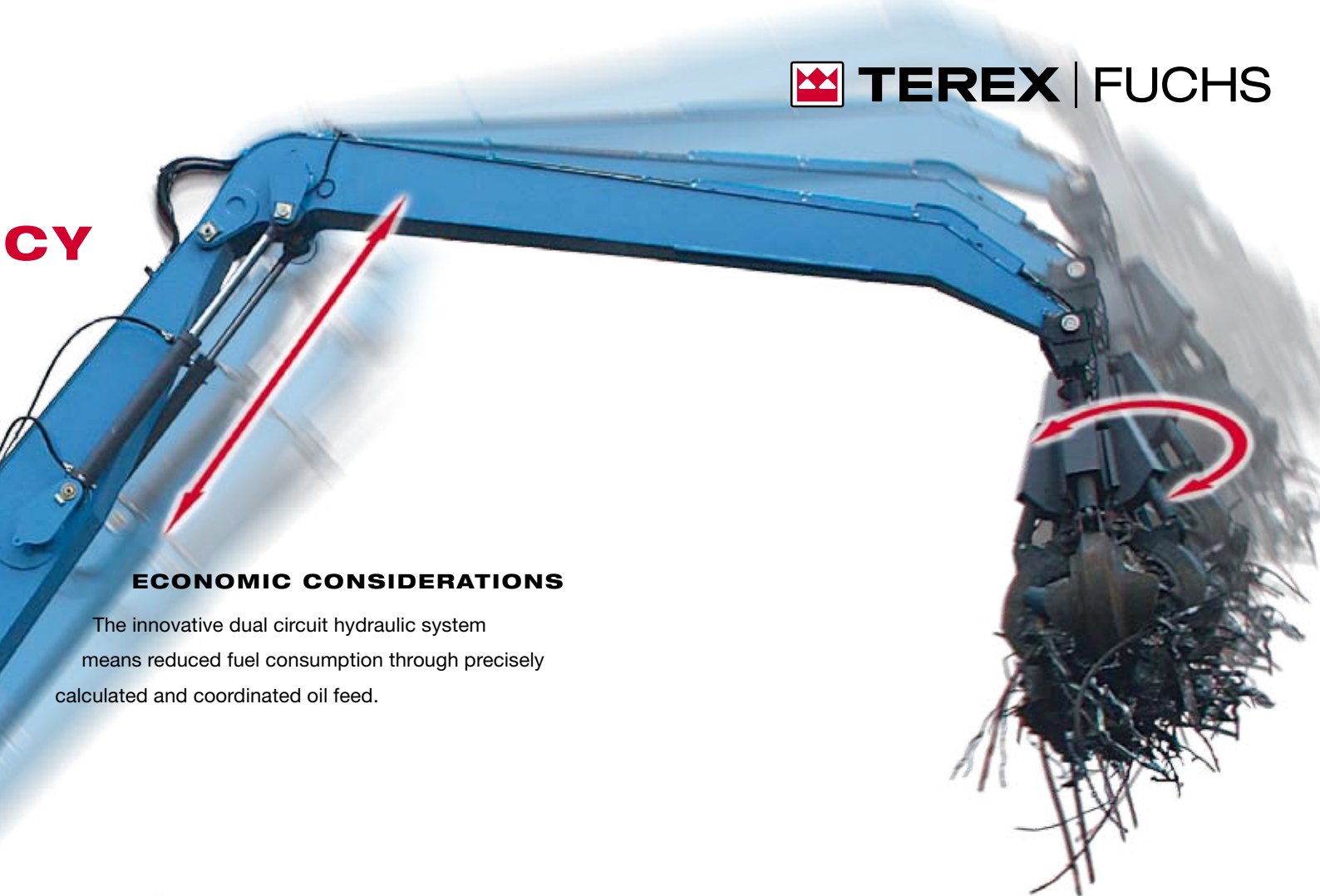

ECONOMIC CONSIDERATIONS

The innovative dual circuit hydraulic system means reduced fuel consumption through precisely calculated and coordinated oil feed.

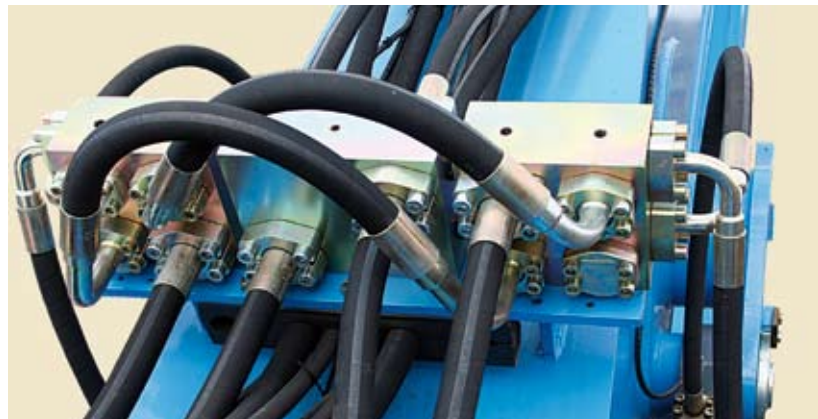
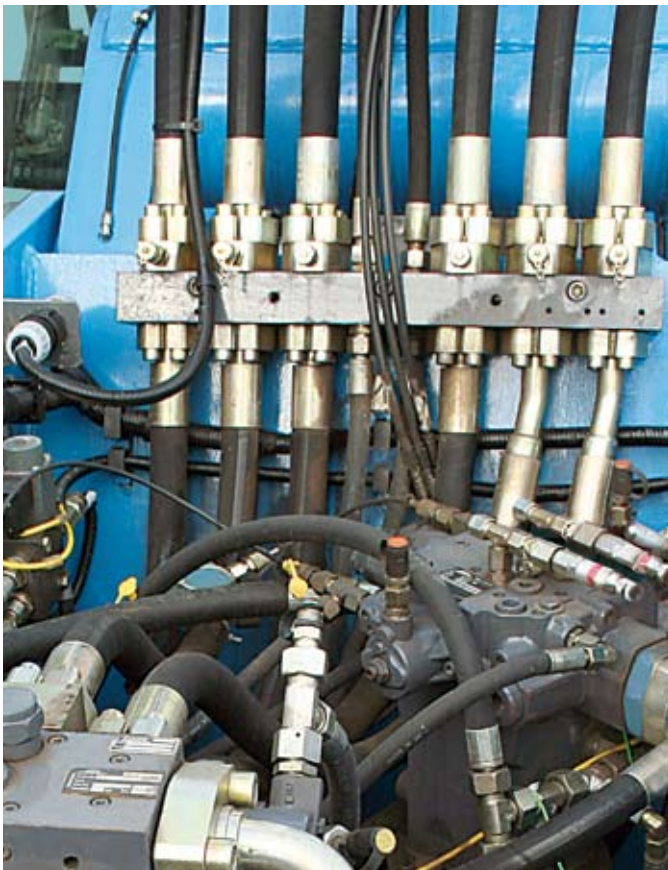

HYDRAULIC SYSTEM SPECS AT A GLANCE

- ▶ Dual circuit hydraulic system provides ultra high efficiency
- ▶ Dipperstick/grab and dipperstick/boom movements either singly or in smoothly blended combination
- ▶ Power loss kept to a minimum when actuators vary
- ▶ Fast working cycles



**SEPARATE COOLING KEEPS MORALE AND CLIMATE AT
STEADY 5-STAR LEVEL**

EASY TO SERVICE

Component parts all defy dirt. The easily accessible maintenance platform facilitates servicing substantially; components are located within easy view and reach. Platform access is via side-mounted maintenance access steps. Radiator, intercooler and oil-cooler are within easy reach from the ground.



COOLING SYSTEM SPECS

AT A GLANCE

- ▶ Operating temperatures up to 50°C ambient air temperature
- ▶ Excellent cooling performance and low noise emissions
- ▶ Hydrostatically driven oil-cooling fan
- ▶ Thermostatically controlled oil cooling fan speeds
- ▶ Fan drive via viscous coupling in water/charge-air cooling system

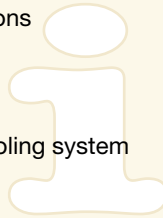

The proven, separate cooling system insures ideal temperatures prevail at every point of machine when in operation. Operating temperature is constantly kept at an optimum level.



MASTER OF ALL YOU SURVEY

ENGINEERING FOR CUTTING-EDGE NO-SWEAT CONTROL

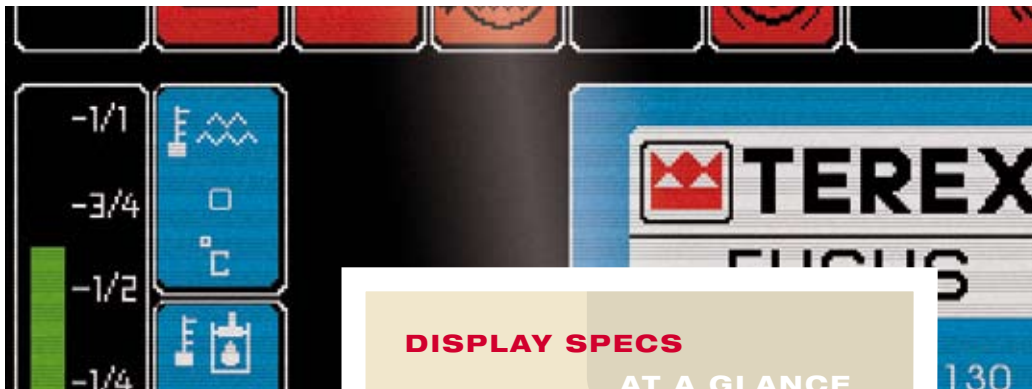

DISPLAY SPECS

AT A GLANCE

- ▶ Easy-to-scan color display
- ▶ Servicing and maintenance made easier via rapid screening of all operationally relevant data
- ▶ Comfortable user-interface with intuitively understandable symbols and user friendly text messages

Our new control system is your dependable partner no matter what the assignment is. Thanks to a high-resolution color display, all relevant equipment data are constantly within view. You maintain constant awareness of essential operating conditions, such as fuel remaining, coolant temperature and hydraulic oil temperature.



WORKING DIAGRAM

MHL 350 (SERIES-D) REACH 16 m (52')

Work equipment:
box-type boom 8.5 m,
dipperstick 7.2 m

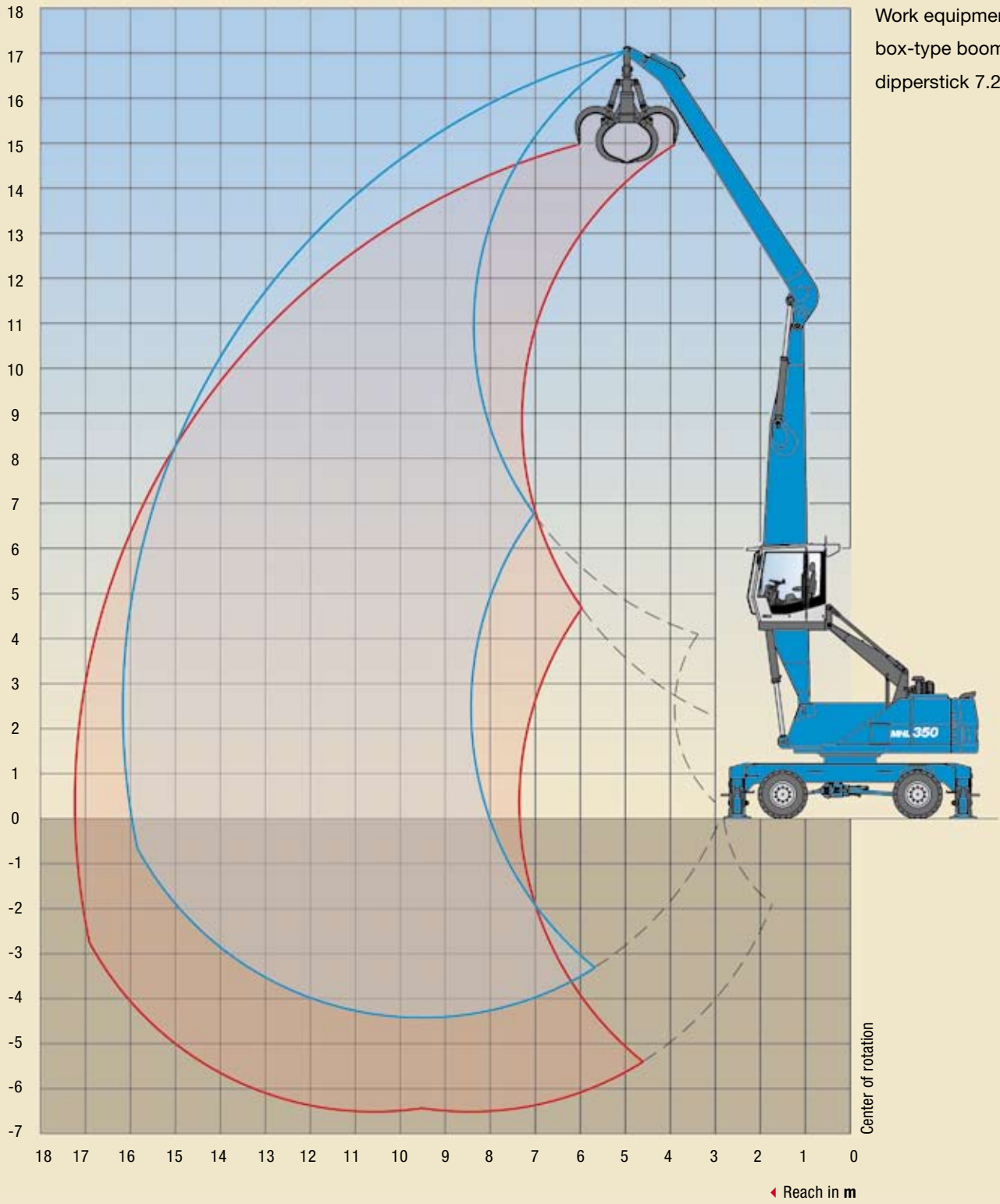

LIFTING CAPACITY

MHL 350 (SERIES-D) REACH 16 m (52')

HEIGHT m	UNDERCARRIAGE STABILIZERS	REACHES m							
		4.5	6	7.5	9	10.5	12	13.5	15
16.5	non supported		(4.2*)						
	4-pt. supported		4.2* (4.2*)						
15	non supported			(4.6*)	(3.3*)				
	4-pt. supported			4.6* (4.6*)	3.3* (3.3*)				
13.5	non supported				(4.7*)	(3.5*)			
	4-pt. supported				4.7* (4.7*)	3.5* (3.5*)			
12	non supported				(5.4*)	(4.3)	(3.2*)		
	4-pt. supported				5.4* (5.4*)	4.6* (4.6*)	3.2* (3.2*)		
10.5	non supported				(5.7)	(4.3)	(3.4)	(2.6*)	
	4-pt. supported				5.9* (5.9*)	5.3* (5.3*)	4.3* (4.3*)	2.6* (2.6*)	
9	non supported				(5.6)	(4.3)	(3.3)	(2.6)	
	4-pt. supported				6.2* (6.2*)	5.6* (5.6*)	5.1* (5.1*)	3.7* (3.7*)	
7.5	non supported			(7.2*)	(5.5)	(4.2)	(3.3)	(2.6)	(2.1)
	4-pt. supported			7.2* (7.2*)	6.4* (6.4*)	5.7* (5.7*)	5.1* (5.1*)	4.3 (4.5*)	2.8* (2.8*)
6	non supported			(7.1)	(5.2)	(4.0)	(3.2)	(2.5)	(2.0)
	4-pt. supported			7.8* (7.8*)	6.7* (6.7*)	5.9* (5.9*)	5.1 (5.2*)	4.2 (4.6*)	3.5 (3.7*)
4.5	non supported	(10.1*)	(9.4)	(6.6)	(4.9)	(3.8)	(3.0)	(2.4)	(2.0)
	4-pt. supported	10.1* (10.1*)	10.6* (10.6*)	8.4* (8.4*)	7.1* (7.1*)	6.1* (6.1*)	5.0 (5.3*)	4.1 (4.7*)	3.4 (4.1*)
3	non supported	(13.0)	(8.4)	(6.0)	(4.6)	(3.6)	(2.9)	(2.4)	(1.9)
	4-pt. supported	16.9* (16.9*)	11.7* (11.7*)	9.0* (9.0*)	7.4* (7.4*)	5.9 (6.2*)	4.8 (5.4*)	4.0 (4.7*)	3.4 (4.0*)
1.5	non supported	(5.3*)	(7.5)	(5.5)	(4.2)	(3.4)	(2.7)	(2.3)	(1.9)
	4-pt. supported	5.3* (5.3*)	12.5* (12.5*)	9.4* (9.4*)	7.2 (7.6*)	5.7 (6.3*)	4.7 (5.4*)	3.9 (4.6*)	3.3 (3.9*)
0	non supported	(3.8*)	(6.9)	(5.1)	(4.0)	(3.2)	(2.6)	(2.2)	(1.8)
	4-pt. supported	3.8* (3.8*)	9.2* (9.2*)	8.9 (9.5*)	6.9 (7.6*)	5.5 (6.3*)	4.5 (5.3*)	3.8 (4.5*)	3.3 (3.7*)
-1.5	non supported	(3.9*)	(6.5)	(4.8)	(3.8)	(3.1)	(2.5)	(2.1)	(1.8)
	4-pt. supported	3.9* (3.9*)	7.1* (7.1*)	8.7 (9.1*)	6.7 (7.3*)	5.4 (6.0*)	4.4 (5.0*)	3.8 (4.1*)	3.2* (3.2*)
-3	non supported		(6.4)	(4.7)	(3.7)	(3.0)	(2.5)	(2.1)	
	4-pt. supported		6.8* (6.8*)	8.3* (8.3*)	6.5 (6.7*)	5.3 (5.5*)	4.4 (4.5*)	3.6* (3.6*)	

The values are stated in tons (t). The pump pressure for this table is 360 bar (5,221 psi). The values amount to 75 % of the static tipping load or 87 % of the hydraulic lifting force (marked *), in accordance with ISO 10567. When the machine is standing on solid and level ground, these values apply to slewing operations through 360°. The values in brackets apply in the lengthwise direction of the undercarriage. The values specified "non-supported" only apply when the load is hoisted above the front or rear axle. The weight of the attached load hoisting implement (grab, magnet, load hook) must be deducted from the carrying capacity values. If the TEREX Fuchs quick-attach system is mounted on the boom, carrying capacity values are reduced by 300 kg (660 lbs). In accordance with EC guidelines, hose-rupture safety valves on the lift cylinders and an overload warning device are required for crane operations.

TECHNICAL DATA

MHL 350 (SERIES-D)



OPERATING WEIGHT	
	Basic machine with work attachment 32 t - 35.5 t (70,548 lbs - 78,264 lbs)
DIESEL ENGINE	
MANUFACTURER AND MODEL	Deutz TCD 2013 L06 2V
DESIGN	6 Cylinder Inline
ENGINE CONTROL	EMR III
TYPE	4-stroke diesel engine, direct common-rail fuel-injection, turbocharger with intercooling
ENGINE OUTPUT	148 kW (198 HP)
NOMINAL SPEED	2000 min ⁻¹
DISPLACEMENT	7.2 l (436 cu in)
COOLING SYSTEM	Liquid cooling, thermostatically controlled and charge air cooling
EMISSION STANDARDS	COM III and EPA Tier III
AIR FILTER DESIGN	Two-stage filter with safety valve
FUEL CAPACITY (USABLE)	383 l (100.6 US Gal)

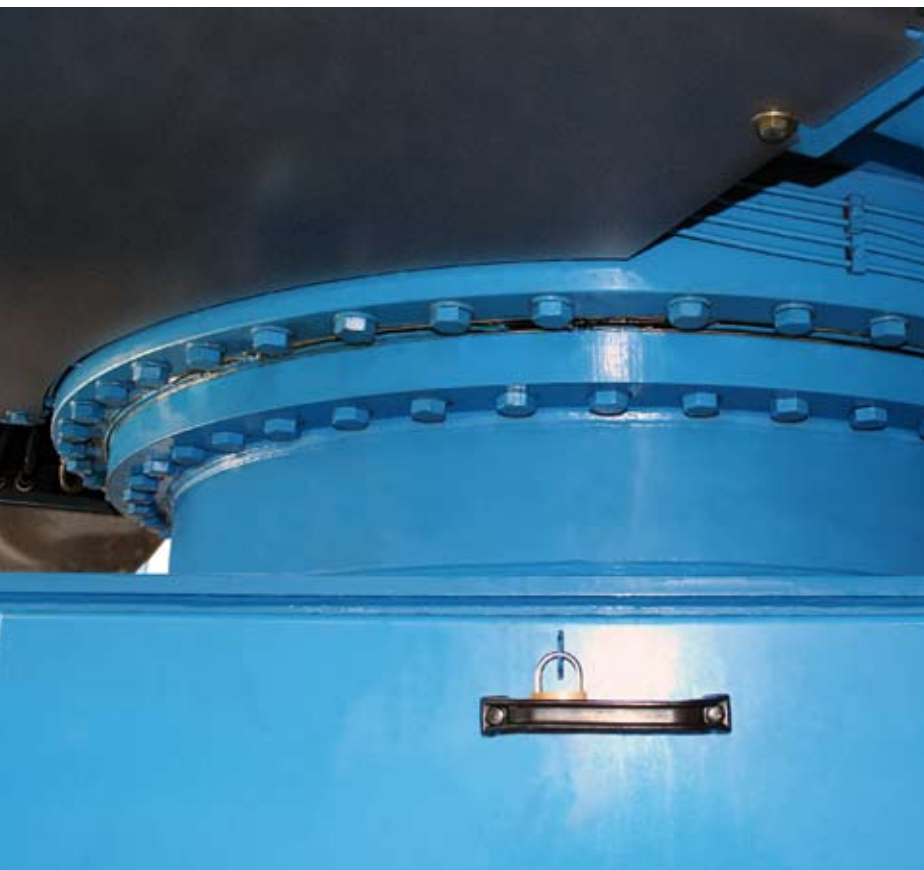

ELECTRICAL SYSTEM	
OPERATING VOLTAGE	24 V
BATTERIES	2 x 12 V / 100 Ah / 760 A (in accordance with EN)
LIGHTING SET	1 dipper-stick-mounted floodlight, 1 headlight mounted to upper carriage, 1 floodlight attached to cabin floor, rear side-marker and turn signal lamps
OPTION	Magnet system 13 kW or 20 kW

TRAVEL DRIVE	
	Hydrostatic drive through infinitely variable axial piston motor and directly mounted travel brake valves, two-speed power shift gear, 4-wheel drive
TRAVEL SPEED 1ST GEAR	max. 5 km/h (3.1 mph)
TRAVEL SPEED 2ND GEAR	max. 20 km/h (12.4 mph)
GRADEABILITY	max. 45%
TURNING RADIUS	8.6 m (28'2")

SWING SYSTEM	
RING GEAR	Internally toothed ball ring gear (double row)
DRIVE	Three-stage planetary gear with integrated multi-disc brake
UPPER CARRIAGE SWING SPEED	infinitely variable from 0 - 8 min ⁻¹
PIVOT BRAKE	Electrically operated

UNDERCARRIAGE	
FRONT AXLE	Planetary drive axle with integrated drum brake, rigidly mounted, max. steering angle: 27°
REAR AXLE	Oscillating planetary drive rear axle with integrated drum brake and selectable oscillating axle lock
STABILIZERS	4-point-stabilizers
TIRES	Solid rubber, elastic tires 8-fold 12.00 - 20

BRAKE SYSTEM	
SERVICE BRAKE	Hydraulic single-circuit braking system, acting on all four wheel pairs
PARKING BRAKE	Electrically operated disc brake, acting on both front and rear axle

HYDRAULIC SYSTEM	
	LINDE mobile hydraulic system with load limit control and fuel conserving power demand control. Separate oil cooler with large cooling surface, temperature controlled fan speed.
HYDRAULIC OIL FILTER	Hydraulic oil filter integrated in the oil tank; maintenance interval: 3.000 operating hrs. Central lubricating system
MAX. PUMP CAPACITY	2 x 320 l/min (2 x 84.6 US Gal/min)
MAX. OPERATING PRESSURE	320/360 bar (4.640/5.221 psi)
HYDRAULIC OIL TANK	389 l (102.5 US Gal)

CAB	
	Infinitely variable hydraulically height-adjustable with max. eye level of 5.8 m/19'06", elastically supported, sound-deadened, heat-insulated panoramic windows for optimum all-around view, windshield with pull-down sunblind that slides under cab roof, viewing window in cab roof, sliding window in cab door, steering column height and tilt adjustable
HEATING	Infinitely variable hot water heating with 3-speed fan, 4 adjustable defroster nozzles
OPERATOR'S SEAT	Air-cushioned comfort-seat with integrated headrest, safety-belt and lumbar support, seat-heating optional. Seat position, seat inclination and seat cushion multi-adjustable in line with position of armrests and pilot control units, allowing fatigue-free operation.
MONITORING	Ergonomic instrument layout, glare-free, function display; automatic monitoring, warning and storage of deviating operating conditions, e.g. filter pressure w. warning indicator and shutdown of pilot controls, warning indicator resp. shutdown of pilot controls when exceeding hydraulic oil temperature limits.
AIR CONDITION	Automatic
ACOUSTIC POWER LEVEL	(guaranteed) in accordance with guideline 2000/14 EG = 102 dB(A) – required in accordance with 2000/14 EG = 104 dB(A)
SAFETY INSTALLATIONS	
	Required when machine is used for crane operations in accordance with EN 474-5
	Cab protection by close proximity range limiter
OFFICIAL HOMOLOGATION	
	Certification according to CE-regulations

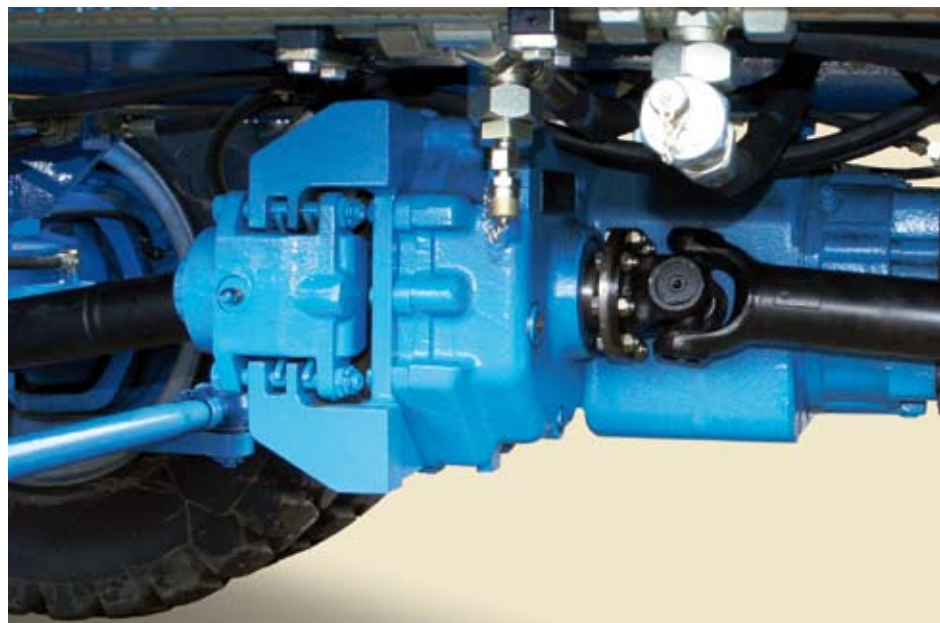

EQUIPMENT

MHL 350 (SERIES-D)

ENGINE	SERIES	OPTION
Turbocharger	●	
Intercooling	●	
Direct electronic fuel injection/Common Rail	●	
Automatic idle	●	
Engine pre-heating		●
Interface for engine diagnosis	●	
Fan drive temperature controlled	●	
UNDERCARRIAGE	SERIES	OPTION
2-speed power-shift transmission	●	
4-point stabilizers	●	
4-point stabilizers individually controllable		●
Stabilizer cylinders with integrated two-way check valves	●	
Differential all-wheel drive	●	
Piston rod protection on support cylinder	●	
Stabilizer plate 430 x 600 mm (17" x 24")	●	
Rear axle oscillating lock	●	
Dozer blade in addition to 4-point stabilizers		●
Special paint		●
Drum brakes	●	
Tool box	●	
SUPERSTRUCTURE	SERIES	OPTION
Electrical refueling pump		●
Lighting protection		●
Maintenance hood, actuated by gas spring, with mechanical locking device	●	
Lockable cleaning access openings on radiator	●	
Separate radiator system for ambient temperatures up to 50°C	●	
Separate oil cooler with temperature controlled fan drive	●	
Automatic central lubrication system	●	
Back-up alarm		●
Special paint		●

CAB	SERIES	OPTION
Lift-up skylight in cabin roof	●	
Document clamp	●	
Air cushioned operator's seat with headrest, safety belt and lumbar-support	●	
FOPS-Protective guard		●
Up and over type front windshield	●	
Front-windows shatter-proof (LEXAN)		●
Cab elevation, 1 m (3'3"), rigid		●
Cab system, height adjustable	●	
Air condition, automatic	●	
Steering column, height and tilt adjustable	●	
Multi function display	●	
Bulletproof glass, front and top		●
Fire extinguisher, dry powder		●
Preparation for radio		●
Flashing alarm light		●
Sliding window in cab door	●	
Safety glass	●	
Seat heating		●
Auxiliary heating		●
Stereo cassette radio		●
Stereo CD radio		●
Windscreen washer system	●	
EQUIPMENT	SERIES	OPTION
Floodlight, attached to cab floor	●	
Floodlight, mounted to superstructure	●	
Floodlight, dipper-stick mounted	●	
Hydraulic oil preheating		●
Close proximity range limiter for dipperstick	●	
Coolant and hydraulic oil monitoring system	●	
Pipe break protection for lift/ boom cylinder		●
Pipe break protection for lift cylinder		●
Dipper stick shock protection	●	
Lubrication of grab suspension by central lubrication system	●	
Overload warning / shut-off installation		●
XENON-floodlight on dipper stick		●
XENON-floodlight on superstructure		●
XENON-floodlight on cab roof		●
Quick release coupling on the dipperstick	●	



RECOMMENDED ATTACHMENTS

MHL 350 (SERIES-D)

WORK ATTACHMENT 16.0 m	
LOAD HOOK	10 t
TEREX Fuchs CACTUS GRAB 0.6 m³	Open or half-shell tines
TEREX Fuchs MAGNET PLATE MP 1150	diameter = 1150 mm with 13 kW magnet installation
TWO-SHELL GRAB 1.0 m³	Material density up to 800 kg/m ³
WORK ATTACHMENT 15.0 m	
LOAD HOOK	10 t
TEREX Fuchs CACTUS GRAB 0.6 m³	Open or half-shell tines
TEREX Fuchs CACTUS GRAB 0.8 m³	Open or half-shell tines
TEREX Fuchs MAGNET PLATE MP 1250	diameter = 1250 mm with 20 kW magnet installation
TWO-SHELL GRAB 1.0 m³	Material density up to 1600 kg/m ³
TWO-SHELL GRAB 1.6 m³	Material density up to 800 kg/m ³
WORK ATTACHMENT 14.0 m	
LOAD HOOK	10 t
TEREX Fuchs CACTUS GRAB 0.6 m³	Open or half-shell tines
TEREX Fuchs CACTUS GRAB 0.8 m³	Open or half-shell tines
TEREX Fuchs MAGNET PLATE MP 1250	diameter = 1250 mm with 20 kW magnet installation
TWO-SHELL GRAB 1.4 m³	Material density up to 1600 kg/m ³
TWO-SHELL GRAB 2.0 m³	Material density up to 800 kg/m ³



DIMENSIONS

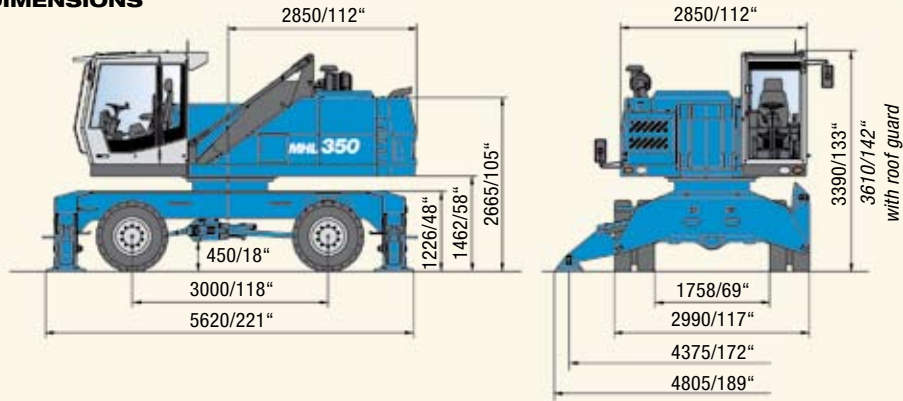

TRANSPORT DIMENSIONS

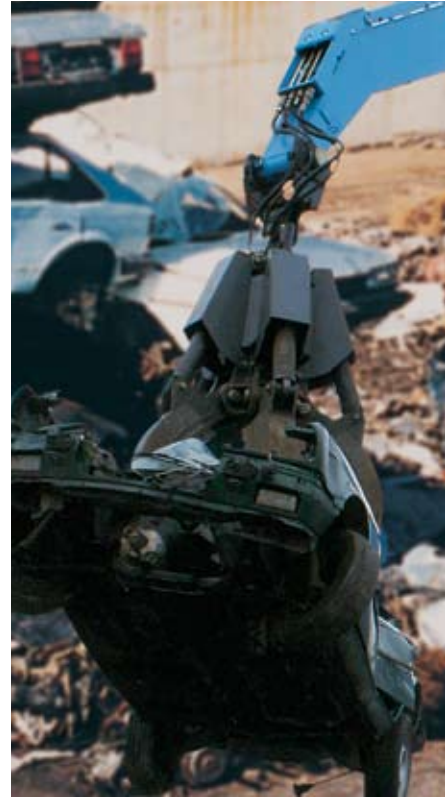
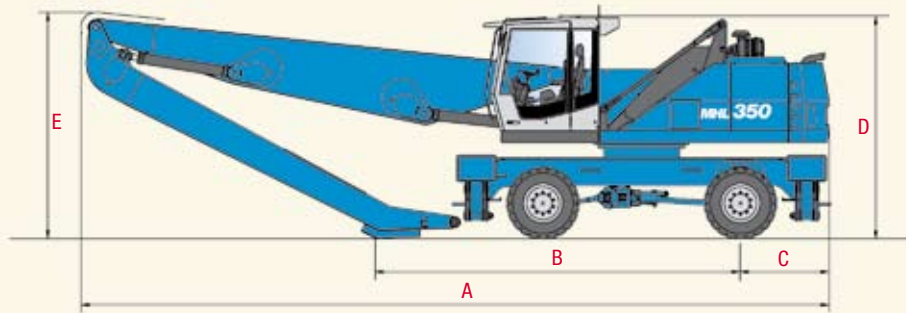

DIMENSIONS	REACH 14.0 m (46')	REACH 15.0 m (49')	REACH 16.0 m (52')
A	11,375 mm (448")	12,610 mm (496")	12,565 mm (495")
B	5,465 mm (215")	6,445 mm (254")	5,605 mm (221")
C	1,350 mm (53")	1,350 mm (53")	1,350 mm (53")
D	3,390 mm (133") * 3,610 mm (142")	3,390 mm (133") * 3,610 mm (142")	3,390 mm (133") * 3,610 mm (142")
E	3,445 mm (136")	3,020 mm (119")	3,600 mm (142")

* with roof guard



DEALER

